



## SGC 420 Mk II functions

### Monitor

- Single phase, 2-phase, 3-phase, and split-phase voltage, frequency, load current, and power factor.
- Engine safety parameters. For example, engine temperature, oil pressure and fuel level.
- Site battery and shelter temperature
- Fuel theft protection

### Control

- Coolant temperature
- Idle speed
- Auto fuel transfer
- Genset and mains breaker
- Fuel relay and crank

### Running modes

The SGC 420 Mk II controller has an AUTO mode, a MANUAL mode, and a TEST mode.

Use the night restriction function to control when the genset operates.

### Operation modes

In AUTO mode, the controller supports these applications:

- Site battery and shelter temperature monitoring
- Automatic mains failure (AMF)
- Cyclic
- Remote start/stop
- Auto exercise
- Engine drive

You can also use the auto start/stop function in AUTO.

### Battery charging alternator

I/O interface for the alternator that charges the battery.

### Counters

- Engine start, engine trips, and engine running hours
- Genset and mains kWh, kVAh, kvarh
- Maintenance

### Smart Connect Mk II software

- **Analogue comparator:** Compare analogue values and create custom alarms.
- **Languages:** Change and customise the controller and software language.
- **Data logging:** Customise the data you want to log. It is also possible to save the logged data.
- **Configuration comparison tool:** Compare customised files with a default set of files.
- **Multiple profiles:** You can configure multiple profiles
- **Live data supervision**
- **M-Logic**

## About SGC 420 Mk II

The SGC 420 Mk II controller contains all the functions needed to protect and control a genset, a genset breaker, and a mains breaker. The controller also has a deep sleep function. This function stops all standard controller functions when the genset is not in operation, which extends the battery life.

The values and alarms are shown on the LCD display screen and operators can easily control the system from the display.

Use the Smart Connect Mk II software to configure parameters, log data, and supervise live data. M-Logic is also available from the software, which allows you to create custom functions using pre-defined events and outputs. The analogue comparator can be used to create custom alarms and logic functions.

## Display and language functions

### Display and language

The display is a full graphics LCD display and backlit. Use the buttons on the controller to control the genset breaker and the mains breaker, and to acknowledge alarms. You can also configure parameters from the display.

The controller supports many language, for example, English, Chinese and Spanish. Use the Smart Connect Mk II software to configure and customise the controller and software language.

### Password protection and event logs

The controller has two password levels that you can configure on the controller.

The controller has an event log for 100 events with real-time clock stamps and engine running hours information. EEPROM is also available for extended event logs.

**Engine drive and island**

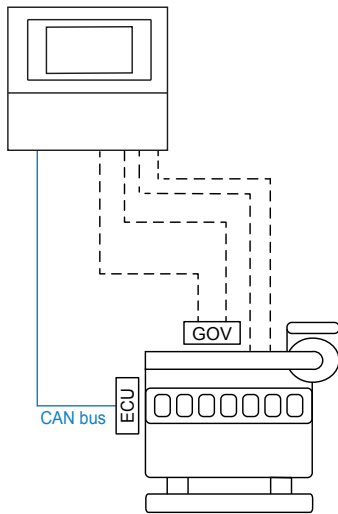

**Engine drive**

Use the SGC to control one engine. The controller has all the functions necessary to protect the engine.

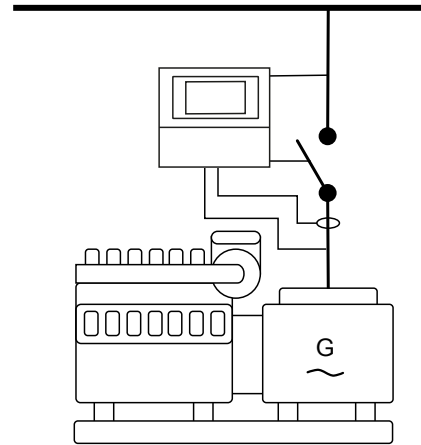

**Island**

Island mode is typically used in power plants that are isolated from other power generation systems.

**Automatic mains failure (AMF) and site battery monitoring**

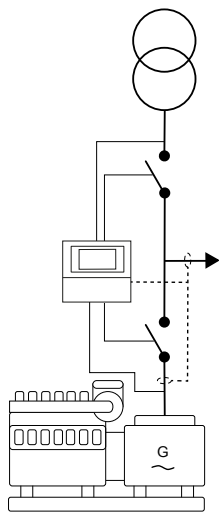

**AMF**

If there is a significant loss of mains power or a total blackout, the controller automatically changes the supply to the generator\*.

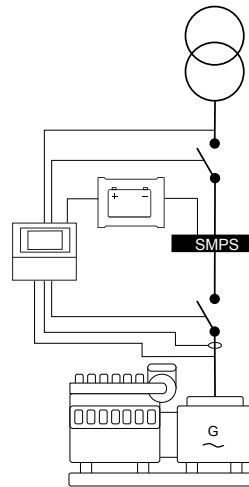

**Site battery**

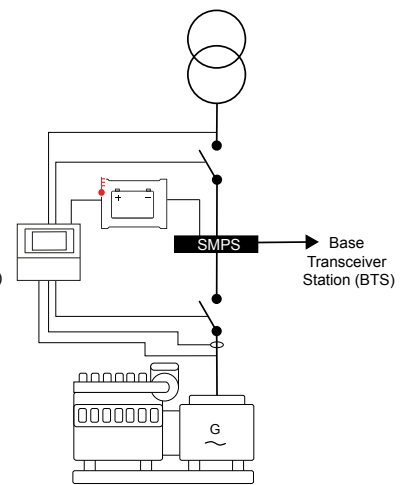

**Shelter temperature**

**Site battery monitoring**

The controller can monitor the site battery and the shelter temperature. The controller can control the battery charge and make sure the battery is sufficiently charged.

**NOTE** \* You can place the CT on the line from the genset or on the load side.

Typical wiring

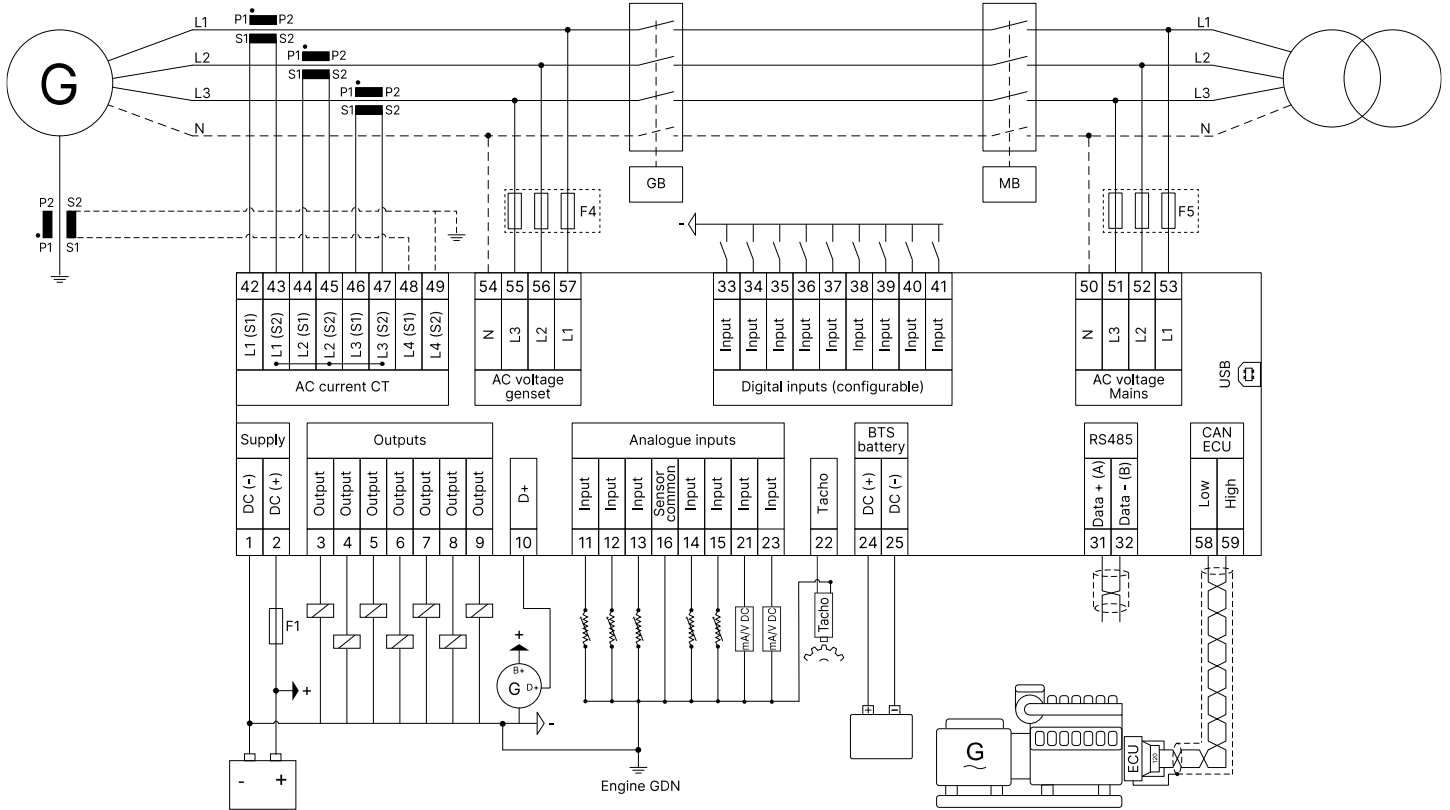

**NOTE** The S2 terminals are internally short.

Communication

- Modbus RS-485
- CAN bus for engine communication
- USB interface to PC

Approvals

- CE
- UL



**More information**

See [www.deif.com](http://www.deif.com) for the newest approvals

### Power supply

- Nominal voltage: 12/24 V DC
- Operating range: 8 to 32 V DC

### Environment

- Operating temperature: -20 to +65 °C (-4 to +149 °F)
- Storage temperature: -30 to +75 °C (-22 to +167 °F)
- Humidity: 0 to 95 % RH
- Protection degree: IP65 in panel
- EMI/EMC: IEC 61000-6-2,4

### Inputs and outputs

- Digital inputs:
  - 9 x switch-to-ground. You can configure 7 switch-to-ground inputs through analogue inputs
  - Negative switching
  - Maximum input voltage: +32 V
  - Minimum input voltage: -24 V
  - Current source: 5 mA
- Digital outputs:
  - 5 x 1 A, configurable
  - 2 x 5 A, configurable
- Analogue inputs:
  - 5 x resistive inputs (10 to 5000 Ω), configurable
  - 2 x 4 to 20 mA/0 to 5 V input, configurable
  - 1 x differential input ( $\pm$  60 V DC)

### Measurements

#### Mains/genset voltage measurements

32 to 300 V AC RMS for phase-neutral, 32 to 520 V AC RMS for phase-phase, 5 to 75 Hz

#### Load current measurements

- Nominal: -/5 A and -/1 A for current transformer (CT) secondary
- 4 CT inputs

#### Magnetic pickup measurements

0.2 to 45 V AC RMS, 10 Hz to 10 kHz

### Dimensions

Dimensions: 233.0 mm (9.17 in) x 173.0 mm (6.81 in) x 38.5 mm (1.52 in)

Panel cut-out: 219.0 mm (8.62 in) x 158.0 mm (6.22 in)

### Protections

1 x Reverse power.....	ANSI 32R
1 x Over-current.....	ANSI 50TD
3 x Over-voltage.....	ANSI 59
3 x Under-voltage.....	ANSI 27P
3 x Over-frequency.....	ANSI 81O
3 x Under-frequency.....	ANSI 81U
1 x Overload.....	ANSI 32F
1 x Under-speed.....	ANSI 14
1 x Overspeed.....	ANSI 12
1 x Unbalanced load	
1 x Low load	
2 x Phase reversal detection	
1 x Earth leakage/Fan current	
1 x Configurable crank connect	
1 x Battery monitoring	
1 x Charging alternator	
1 x Pre-heat	
1 x Coolant temperature	
1 x Lube oil pressure	
1 x Fuel level	
1 x Fuel theft	
1 x ECU communication failure	
1 x ECU diagnostic lamps	
1 x Site battery	
1 x Shelter temperature	

#### For more information:

DEIF A/S

Frisenborgvej 33, 7800 Skive, Denmark

Tel.: +45 9614 9614, info@deif.com

www.deif.com

